

TIPS FOR MASONRY DRILLS (Standard)

Size	Item No.	D		W		T	
		inch	Tol.	inch	Tol.	inch	Tol.
1/8	MDG 2	0.140	+0	0.164		0.035	
5/32	MDG 2.5	0.171	-0.006	0.180		0.035	
3/16	MDG 3	0.206		0.197		0.045	
7/32	MDG 3.5	0.237		0.220	+0.010	0.045	
1/4	MDG 4	0.268	+0	0.220	- 0	0.060	+0
9/32	MDG 4.5	0.304	- 0.008	0.260		0.060	- 0.003
5/16	MDG 5	0.335		0.260		0.060	
3/8	MDG 6	0.398		0.320		0.078	
7/16	MDG 7	0.468		0.375		0.078	
1/2	MDG 8	0.530	+0	0.430		0.091	
9/16	MDG 9	0.592	- 0.010	0.472	+0.015	0.091	
5/8	MDG 10	0.680		0.510	- 0	0.091	+0
3/4	MDG 12	0.787	+0	0.598		0.091	- 0.004
7/8	MDG 14	0.917	- 0.012	0.650		0.091	
1	MDG 16	1.042		0.718		0.122	
1-1/8	MDG 18	1.175		0.758		0.122	
1-1/4	MDG 20	1.300	+0	0.758	+0.020	0.122	+0
1-3/8	MDG 22	1.425	- 0.015	0.843	- 0	0.122	- 0.005
1-1/2	MDG 24	1.550		0.843		0.122	

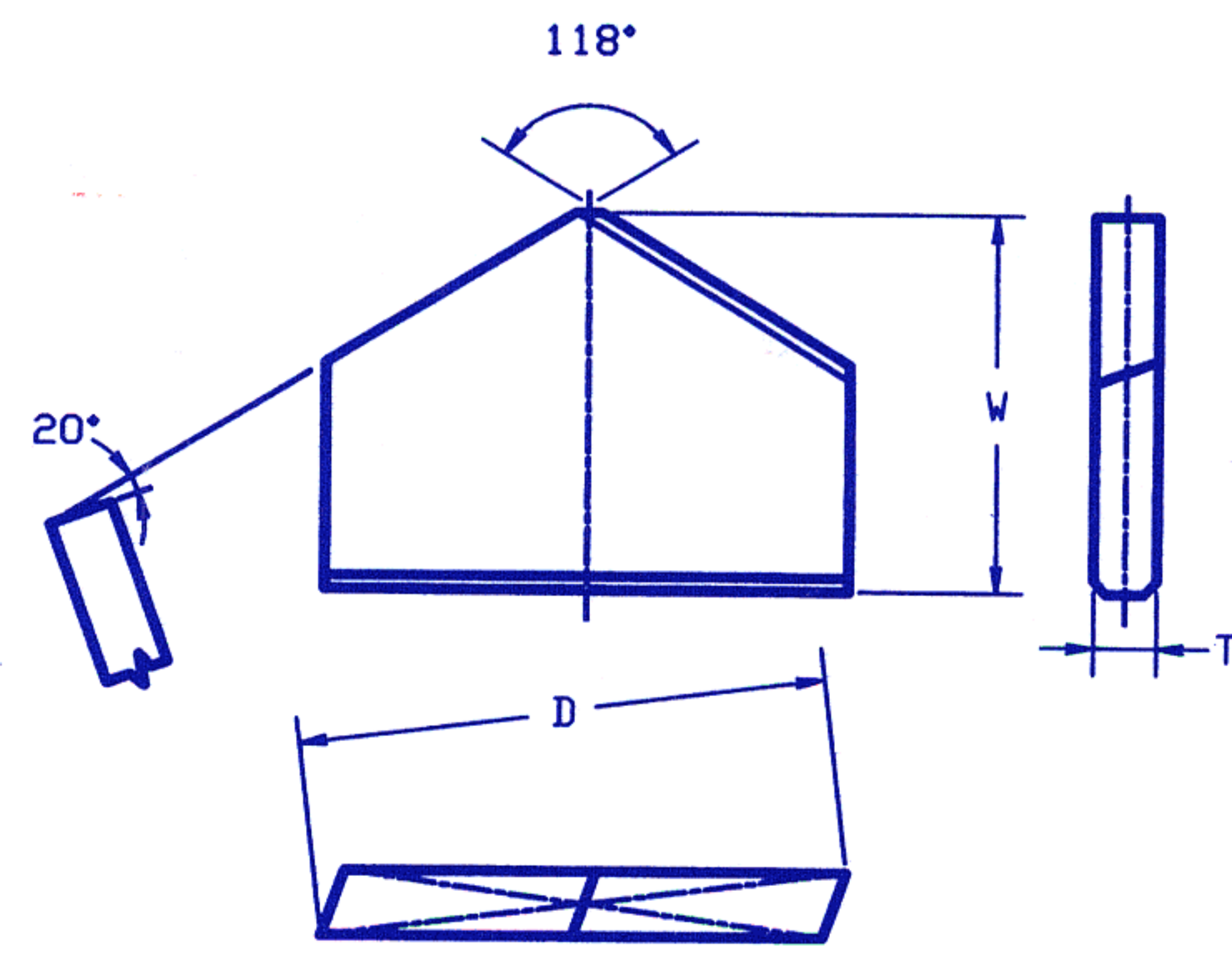

TIPS FOR HAMMER DRILLS

Size	Item No.	D		L		T	
		inch	Tol.	inch	Tol.	inch	Tol.
5/32	HDG 2.5	0.171	+0	0.177		0.039	
11/64	HDG 2.75	0.187	- 0.006	0.197		0.047	
3/16	HDG 3	0.206		0.197		0.047	
13/64	HDG 3.25	0.221		0.220		0.047	
7/32	HDG 3.5	0.237		0.220		0.055	+0
15/64	HDG 3.75	0.252	+0	0.220		0.055	- 0.004
1/4	HDG 4	0.268	-0.008	0.220		0.055	
17/64	HDG 4.24	0.284		0.256		0.063	
9/32	HDG 4.5	0.304		0.256		0.063	
5/16	HDG 5	0.335		0.256		0.078	
3/8	HDG 6	0.398		0.295		0.086	
7/16	HDG 7	0.468		0.334		0.086	+0
1/2	HDG 8	0.530	+0	0.374	+0.008	0.110	- 0.006
9/16	HDG 9	0.592	- 0.010	0.374	- 0	0.118	
5/8	HDG 10	0.680		0.413		0.118	
11/16	HDG 11	0.723		0.433		0.137	
3/4	HDG 12	0.787		0.512		0.137	
13/16	HDG 13	0.849		0.512		0.137	
27/32	HDG 13.5	0.881	+0	0.551		0.157	+0
7/8	HDG 14	0.917	- 0.012	0.551		0.157	- 0.008
15/16	HDG 15	0.980		0.590		0.177	
1	HDG 16	1.042		0.590		0.177	
1-1/8	HDG 18	1.175		0.669		0.196	
1-1/4	HDG 20	1.300	+0	0.748		0.216	
1-3/8	HDG 22	1.425	- 0.015	0.748		0.216	
1-1/2	HDG 24	1.550		0.827		0.236	

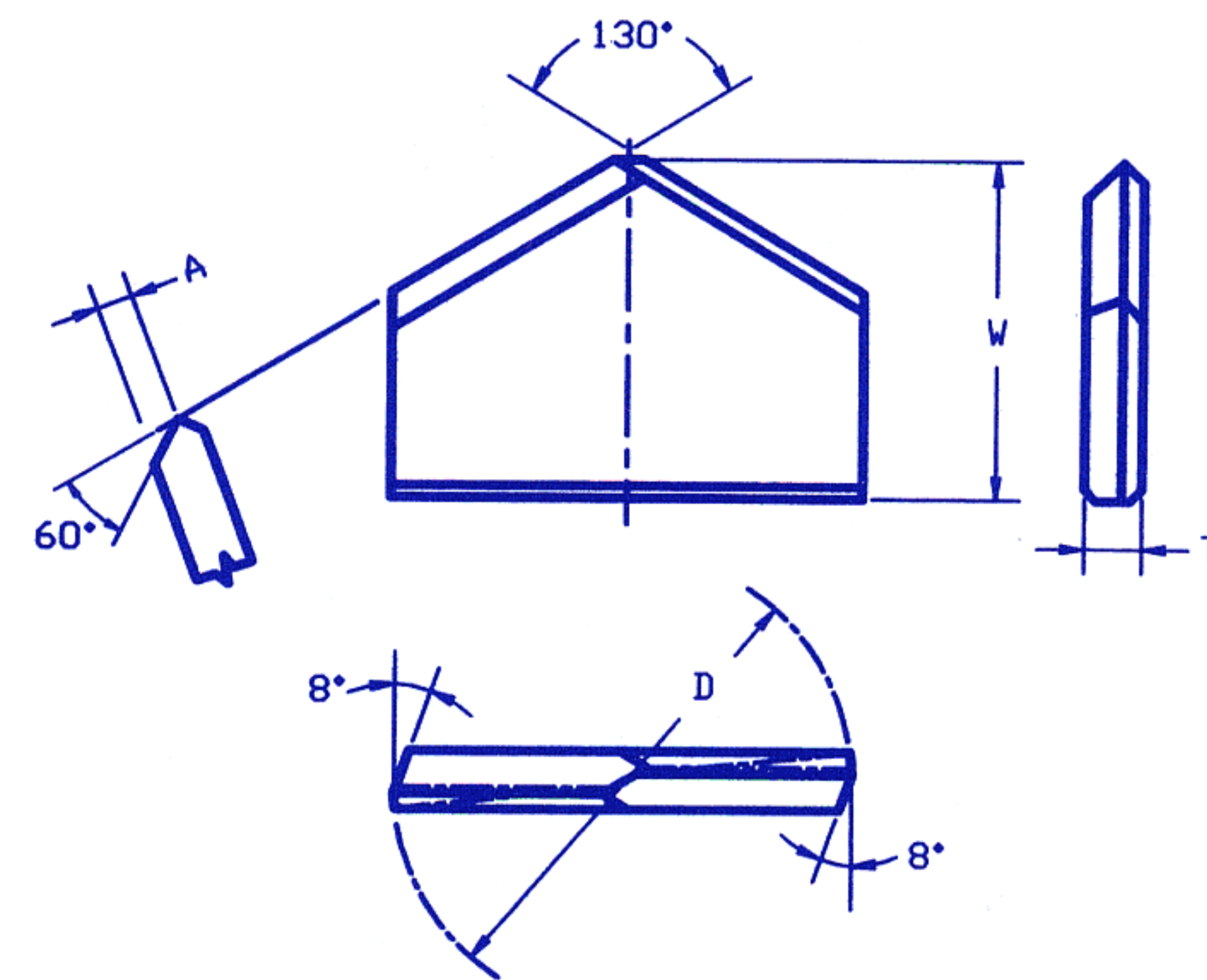

See important safety information on the inside front cover.